

MILITARY SPECIFICATION
CV7582-84
SEMICONDUCTOR DEVICE, THYRISTOR

DESCRIPTION: This specification covers the detail requirements for a reverse blocking triode thyristor, and is in accordance with specification K1007, Issue 3, except as otherwise stated.

MECHANICAL DIMENSIONS AND OUTLINE: See Fig. 5

CONNECTIONS: Stud, Anode. No 1 Terminal, Cathode. No 2 Terminal, Gate.

ABSOLUTE MAXIMUM RATINGS:

Device	Ratings	V _R	V _{FD}	I _{FTM}	I _{FT(AV)}	V _{GKM}	P _{GM}	P _{G(AV)}	T _{STG}	SHOCK	Vib.
	Unit	V	V	A	A	V	W	W	°C	g	g
CV7582	Min								-65		
	Max	100	100	18	3	10	5	0.5	+150	1500	20
CV7583	Min								- 65		
	Max	200	200	18	3	10	5	0.5	+150	1500	20
CV7584	Min								- 65		
	Max	400	400	18	3	10	5	0.5	+150	1500	20
	NOTE		A	B	B & D		C	C			

- Notes:-
- A. In off condition.
 - B. Up to 80°C case.
 - C. At T_{stud} = 125°C.
 - D. See derating curve fig. 1.
 - E. Commercial Equivalents 1S601, 2, 4.
 - F. For explanation or symbols see Page 3.

27th July 1964
 (190452)

CV 7582-84

PRIMARY ELECTRICAL CHARACTERISTICS

CHARACTERISTICS		V_F	I_R	I_F	I_G	I_H	V_{GF}	
UNIT		V	mA	mA	mA	mA	V	
MIN		-	-	-	0.25	-	-	
MAX		1.5	1.0	1.0	20	25	3	
CONDITIONS	T_{STUD}	$^{\circ}C$	25	125	125	25	25	
	I_F	A	3					
	I_G	mA		0	0		0 25	
	V_R	CV7582	V		100			
		CV7583	V		200			
		CV7584	V		400			
	V_F	CV7582	V			100		
		CV7583	V			200		
		CV7584	V			400		
		NOTES					F	G

NOTES: F. See circuit in fig. 2

G. See circuit in fig. 3

Reliability Assurance Requirements:-

Under Discussion

Requirements:

Marking The device shall be marked first with the CV number and then according to K1007, Section B 1.3.4.

Quality Assurance Provisions:-

Destructive Tests The tests listed in Group B Inspection Sub Groups 2 and 3, and Group C Inspection Sub Group 2 are considered destructive.

Group C Inspection This inspection shall be conducted on the initial lot, and thereafter every ninety days or every fifth lot, whichever occurs first.

Preparation for Delivery:-

Packaging The device shall be packed according to K1007, Section A 1.2(c)

NATO Stock Numbers:-

CV7582 = 5960-99-037-3858

CV7583 = 5960-99-037-3859

CV7584 = 5960-99-037-3860

The following symbols have been used in this specification:-

V_R = Peak Working Reverse Voltage.

V_{FD} = Peak Forward off-state Voltage.

I_{FTM} = Peak Repetitive Forward Current.

$I_{FT(AV)}$ = Average Rectified Forward Current.

V_{GKM} = Peak Gate to Cathode Voltage.

P_{GM} = Peak Gate Power.

$P_{G(AV)}$ = Average Gate Power.

This specification has been prepared by, and the Qualification Approval Authority is:-
Ministry of Aviation, Royal Radar Establishment, Malvern, Worcs. England.

27th July 1964

Page 3

GROUP A INSPECTION

Examination or Test	Test Conditions		AQL %	Insp. Level	Sym- bol	LIMITS		Units	
	K1007/NATO Ref.	Specific Conditions				Min.	Max.		
<u>SUB GROUP 1</u> Visual and Mechanical Inspection	8C.3.1	Excluding physical dimensions	0.65	I					
		CV7582 $V_R = 100V$ CV7583 $V_R = 200V$ CV7584 $V_R = 400V$ All $I_G = 0$ $T_{stud} = 125^\circ C$							
<u>SUB GROUP 2</u> Reverse Current	8C.5	CV7582 $V_F = 100V$ CV7583 $V_F = 200V$ CV7584 $V_F = 400V$ All $I_G = 0$ $T_{stud} = 125^\circ C$ $I_F = 3A$ $T_{stud} = 25^\circ C$	0.65	II	I_R		1.0	mA	
Forward Current									
Forward voltage drop								1.5	V

GROUP A INSPECTION (Cont'd)

Examination or Test	K1007/NATO Ref.	Test Conditions	AQL %	Insp. Level	Sym- bol	LIMITS		Units
						Min.	Max.	
<u>SUB GROUP 3</u> Gate triggering signal		See fig. 2 $T_{stud} = 25^{\circ}C$	2.5	I	I_G	0.25	20	mA
Gate forward voltage drop		$I_G = 25\text{ mA}$ $I_A = 0$ $T_{stud} = 25^{\circ}C$					3	V
<u>SUB GROUP 4</u> Holding current		See fig. 3	4.0	I_A	I_H		25	mA
Turn-on time		See fig. 4			t_{on}		2.5	μSec
Turn-off time		See fig. 4			t_{off}		25	μSec

GROUP B INSPECTION

Examination or Test	TEST CONDITIONS		Insp. Level	Sym- bol	LIMITS		Units
	K1007/NATO Ref.	Specific Conditions			AQL %	Min.	
<u>SUB GROUP 1</u> Physical dimensions		SO-35A outline	IC				
<u>SUB GROUP 2</u>			IA				
Temperature Cycling	5.5	-65 to +150°C					
Moisture Resistance	5.3						
<u>SUB GROUP 3</u>			IA				
Vibration fatigue	5.15.1	Non operating					
<u>SUB GROUP 4, 5 & 6</u>							
Omitted							
<u>SUB GROUP 7</u>			I				
High temperature life, non operating	6.2.1 6.6.1.2.2	T _{stg} = 150°C Duration = 1000 hours					
<u>SUB GROUP 8</u>							
Operating life	6.3 6.6.1.2.2	At max. rev. voltage. Conduction angle = 90° minimum, f = 50 c/sec. At max forward voltage. Av. rectified forward current selected from the derating curve, fig 1 for the chosen stud temperature. Duration 1000 hours.	IA				

GROUP B INSPECTION (Cont'd)

Examination or Test	Test Conditions K1007/NATO Ref.	AQL %	Insp. Level	Sym- bol	Limits		Unit
					Min.	Max.	
<u>Post Test end points, Sub Groups 2, 3, 7 & 8</u>							
Reverse current	As in Group A, Sub Group 2			I _R		2.0	mA
Forward current	As in Group A, Sub Group 2			I _F		2.0	mA
Forward voltage	As in Group A, Sub Group 2			V _F		1.8	V

GROUP C INSPECTION

Examination or Test	K1007/NATO Ref.	TEST CONDITIONS		AQL %	Insp. Level	Sym- bol	LIMITS		Units
		Specific Conditions					Min.	Max.	
<u>SUB GROUP 1</u>									
Omitted									
<u>SUB GROUP 2</u>									
Shock	5.17		Non operating	6.5	IA				
<u>Post Test End Points for Sub Group 2</u>									
Reverse Current			As in Group A, sub group 2			I _R	2.0	2.0	mA
Forward current			As in Group A, sub group 2			I _F	2.0	2.0	mA
Forward voltage			As in Group A, sub group 2			V _F	1.8	1.8	V

FIG 1

DERATING CURVE

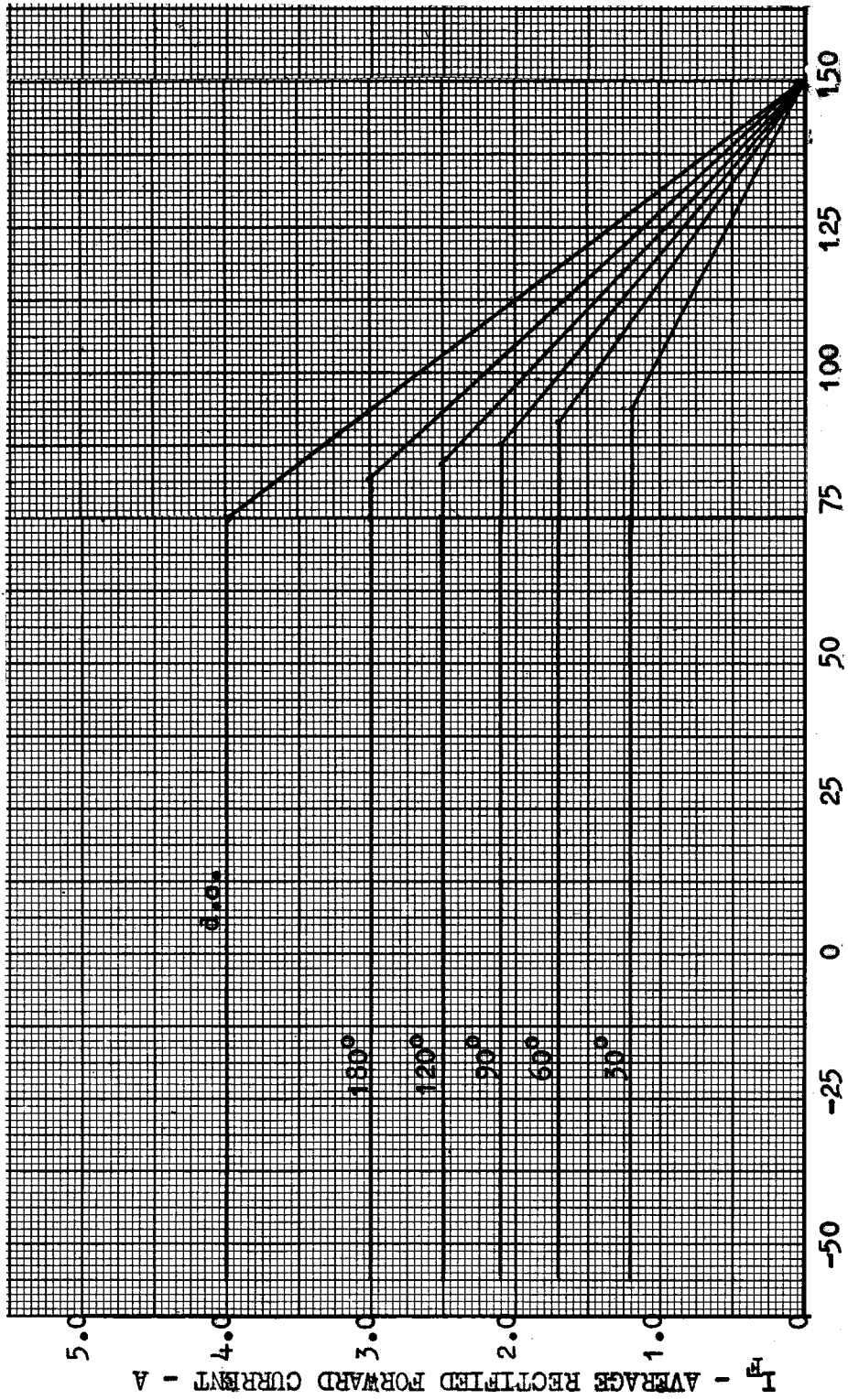

27th July 1964

TEST CIRCUIT FOR GATE TRIGGERING SIGNAL

FIG 2

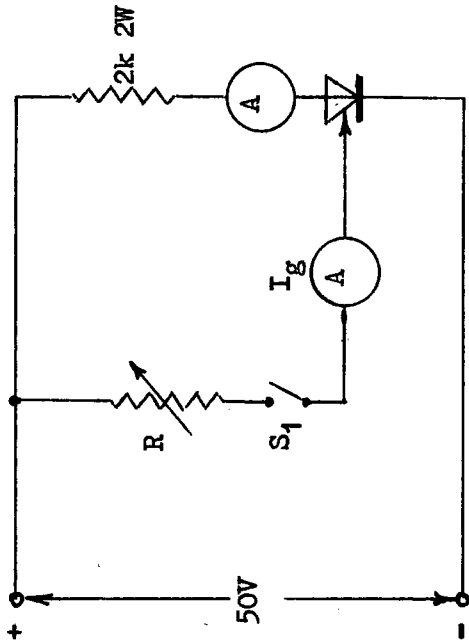

Close S₁ Reduce R until the rectifier switches into conduction. The gate trigger is the value of I_g just prior to conduction.

FIG 3

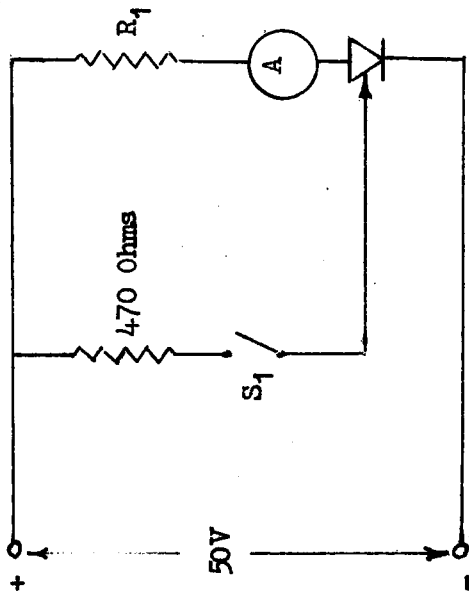

Reduce R₁ until the momentary closure of S₁ just leaves the rectifier in the conducting state. This value of anode current is the holding current.

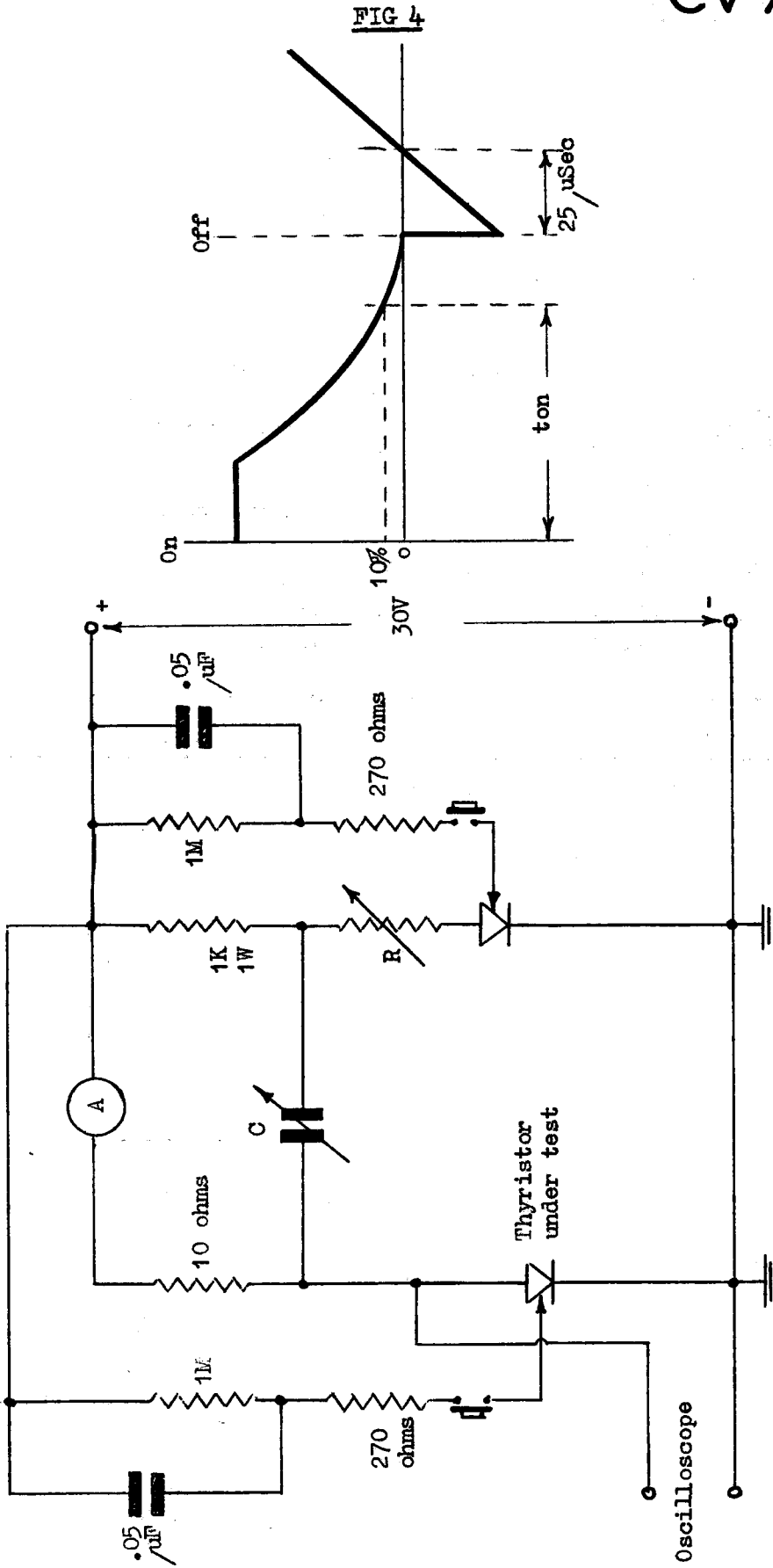

The values of C and R must be chosen so that the Rectifier is reverse biased for a period of 25usecs. Under these conditions the Rectifier must turn off.

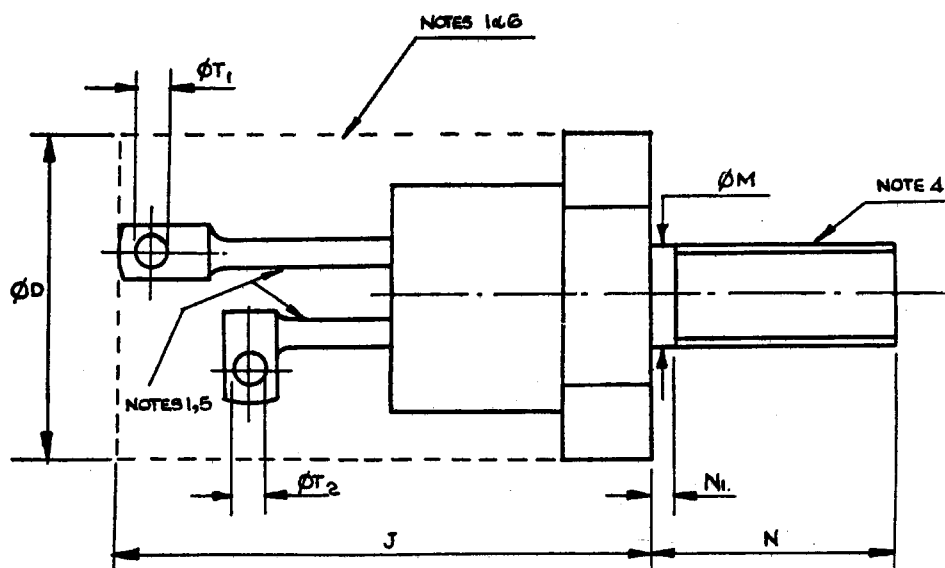

THE MILLIMETRE DIMENSIONS ARE DERIVED FROM THE ORIGINAL INCH DIMENSIONS

REF.	DIMENSIONS							NOTES
	MILLIMETRES			DEGREES	INCHES			
	Min.	Nom.	Max.	Nom.	Min.	Nom.	Max.	
ϕD			12.82				.505	1
J			24.13				.950	
ϕM	3.69		4.82		.145		.190	2
N	10.72		11.50		.422		.453	
N_1			1.98				.078	3
ϕT_1	1.53				.060			
ϕT_2	1.15				.045			

NOTES

1. The device, with the exception of the thread, lies within the cylinder of ϕD and length J.
2. ϕM refers to length N_1 .
3. Dimension N_1 to end of full thread.
4. Thread 10-32 UNF-2A.
5. Terminals are fixed lugs, contour and orientation undefined.
6. This zone includes a 7/16" hexagon [10.75 mm.] .423" min. across flats. [11.12 mm.] .438" max.